

# CSW Multifeeder Resealable 8 - MF-R8

## Automatic end-unwrapper

CSW Multifeeder Resealable 8 (MF-R8) for aluminium can-ends, with a maximum capacity of un-wrapping eight (8) rolls per minute of resealable ends, allowing an intended capacity of 90,000 ends per hour to the downstream seamer/filler equipment of both standard ends as well as resealable ends.

The discharge of the Multifeeder-R8 is connected to the Flexbuffer capable of buffering up to two (2) un-wrapped rolls of ends. The Multifeeder can either be fitted with one Flexbuffer for feeding a single infeed seamer, or can be fitted with two Flexbuffers for a single infeed seamer with two different can-end diameters or two independent single infeed seamers (reducing the guaranteed output to 7 rolls per minute).



*Enlarged driven storage table*



*Paper bin*



*Flexbuffer*

### The MF-R8 has the following features;

- Complete stainless steel structure
- Storage table with optoc ensuring controlled feeding of ends
- Storage capacity of 50 rolls
- Unwrapping unit by means of retractable knife in conjunction with rollers
- Paper bin collector
- Detection system, for detection of reversed ends (manual removal)
- Discharge end conveyor c/w gap-control unit for controlled feeding towards seamer
- Standard 5 meter of can-end conveyor included
- Including E-cabinet and steering & control
- Easy operating and cleaning
- Minimal effort required for maintenance
- 24 hours operation - 7 day a week
- Maximum safety for operating staff

**CSW Guarantees a machine efficiency of minimal 99% according to OEE.**

**your best start in end-unwrapping**

## CSW Multifeeder Resealable 8 - MF-R8

### Technical data

Model	MF-R8
Seamer connection	Single end infeed/double end infeed
Can-ends	Aluminium Resealable as well as standard/CDL/Super-ends
Can-ends per hour	Max. 90,000 (depending on geometrics of resealable ends, number of ends per roll and the seamer infeed behaviour)
Can diameter	2.00 - 2.06 (different end diameters running on one system might result in issuing multiple Flexbuffers)
Roll length (variation)	800 - 1,200 mm
Roll capacity	Max. 8 rolls/ min.
Packing of rolls	Acc. to CSW Roll Requirements
Compressed air	6 bar (g)
Air connection	10 mm
Compressed air consumption	350 NI/min.
E- Power connection	400V @ 50Hz, TN-S
Total connected power	2,5 kW
Peak power consumption	1 kW
Stand by	0,5 kW
Nett weight approx..	1350 kg (MF) + 750 kg (Flex) = 2100 kg Total Weight

Please note that submitted energy consumptions are for indication purposes only. Equipment energy consumption depends on actual system configuration for your specific requirements.

### Options and upgrade kits MF-R8

- Dustcover for can-end transport system
- Driven storage table in various capacities
- Change-over sets for different can-end diameters
- Quick change over time

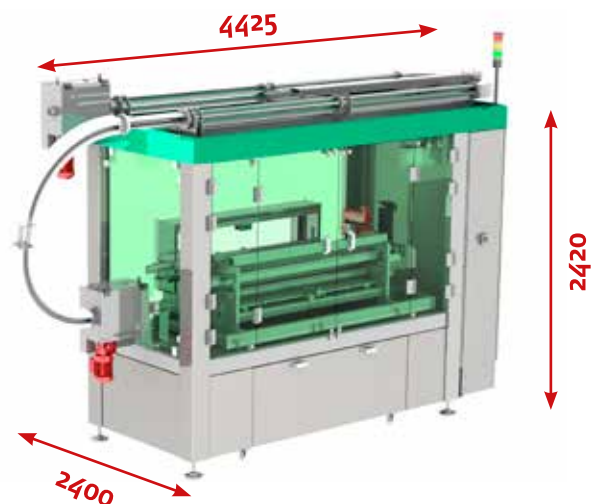

For your specific requirements please contact your CSW representative, call +31 (0) 570 678 700 or find your local CSW representative on [www.cswbv.com/your-agency](http://www.cswbv.com/your-agency).

CSW Machinery B.V.

Rigistraat 16, 7418 EW Deventer

The Netherlands

+31 (0)570 678700

sales@cswbv.nl

[WWW.CSWBV.COM](http://WWW.CSWBV.COM)