

CSW Mini Multifeeder 2 - MMF-2

Automatic end-unwrapper

CSW Mini Multifeeder 2 - MMF-2 for aluminium can-ends as well as steel-ends, with a maximum capacity of un-wrapping two (2) rolls per minute, allowing a guaranteed capacity of 60,000 ends per hour with minimal 500 ends per sleeve, or 72,000 ends per hour with minimal 600 ends per sleeve, to the downstream seamer/filler equipment.



Storage Table



Un-wrapping Section



Paper Bin

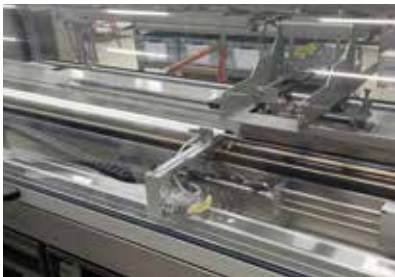

Transfer Section



Can-end Discharge towards seamer



Control Panel

The Mini Multifeeder 2 has the following features;

- Completely stainless steel structure
- Storage table with optoc ensuring controlled feeding of rolls
- Storage capacity of 40 rolls
- Unwrapping unit by means of static knife in conjunction with rollers.
- Paper bin collector
- Sentinel system, for detection and automatic removal of reversed ends
- Discharge end conveyor c/w gap-control unit for controlled feeding towards seamer
- Standard 5 metre of can-end conveyors included
- Easy operating and cleaning
- Minimal effort required for maintenance
- 24-hour operation - 7 day a week.
- Maximum safety for operating staff

CSW guarantees a machine efficiency of minimal 99% according to OEE.

your best start in end-unwrapping

CSW Mini Multifeeder 2 - MMF-2

Technical data

Model	MMF-2	Note
Seamer connection	Single end feed	
Can-ends	Aluminium SOT / Steel	
Can-ends per hour	max. 60,000	
Can diameter	2.00 - 2.09	
Roll length	800 - 1.200 mm	Fixed to one length
Roll variation	+/- 25 mm	
Roll capacity	Max. 2 rolls / min.	
Packing of rolls		Acc. to CSW spec.
Compressed air	6 bar (g)	
Air connection	10 mm	
Compressed air consumption	2,4 Nm ³ /h	
E- Power connection	400V @ 50Hz: TN-S	
Total connected power	2 kW	
Peak power consumption	1 kW	
Stand by	0,2 kW	
Dimensions incl. packaging	5,5 * 2,3 * 2 (mtr.)	
Nett weight approx..	1,350 kg	

Please note that submitted energy consumptions are for indication purposes only, equipment energy consumption depends on actual system configuration for your specific requirements.

Options and upgrade kits MMF-2

- Integrated lift unit for steel lids
- Roll length variation with a max. of 180 mm
- Dustcover for can-end transport system
- Driven storage table in various capacities
- Change over sets for different can-end diameters
- Quick change over time
- Integrated Manual end feed system as bypass

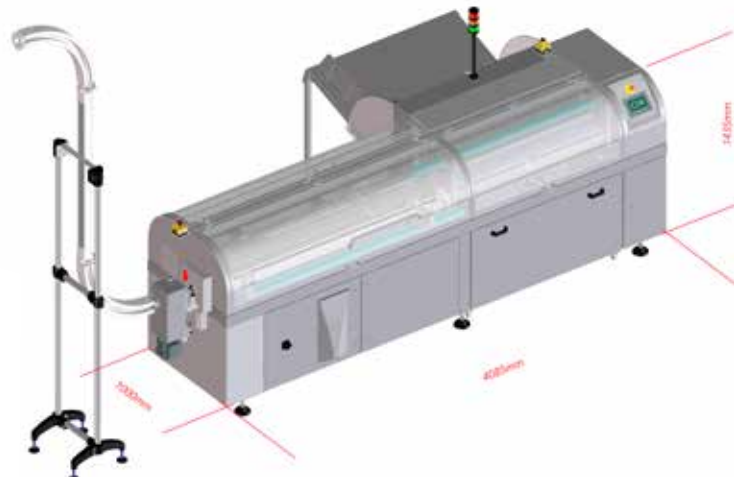

For your specific requirements please contact your CSW representative, call **+31 (0) 570 678 700** or find your local CSW representative on www.cswbv.com/your-agency

CSW Machinery B.V.

Rigastraat 16, 7418 EW Deventer

The Netherlands

+31 (0)570 678700

sales@cswbv.nl

WWW.CSWBV.COM